

Bike Lockers offer optimal protection from the elements, theft and vandalism. The 300 and 350 series bike lockers are a top choice of architects and government agencies. Constructed of durable fiberglass reinforced plastic, they won't rust, dent or chip and are impact and stain resistant. Choose from 8 different models, 7 colors and numerous options best suited for your site.

- Durable fiberglass reinforced plastic lockers for indoor and outdoor applications
- 300 Series lockers come preassembled
- Impact and stain resistant



Bike Lockers 302

© Copyright 2022 Handi-Hut Inc. All Rights Reserved

GENERAL INFORMATION

Materials: Molded fiberglass reinforced plastic composite with a smooth "X" and "Y" pattern on stippled walls and top, with smooth door frame and stippled door (E-glass and polyester resin at 35% ratio)

Colors: (See below)

Security: Pop Out "T" Handle Keyed Lock or Heavy-duty Stainless Steel Padlock/U-Lock Handle

Installation: Anchor securely to surface

Bike Racks: Not included

DIMENSIONS/CAPACITY

Model	Length	Width	Height	Bikes
301	6' 2"	2' 6"	4'	1
301P	6' 1"	2' 6"	4'	1
301V	4' 6"	2' 6"	6'	1
301W	6' 2 ¼"	3' 4"	4'	2-3
301WL	8' 6"	3' 4"	4'	2
301 WXL	10'	3' 4"	4'	*
302 (2 doors)	6' 2 ¼"	3' 4"	4'	2
351	6' 2"	2' 6"	4'	1
352 (2 doors)	6' 2 ¼"	3' 4"	4'	2

Setback: 5' clearance for door(s)

* 1 Cargo Bike or 1 Bike & Kids Trailer

OPTIONS/ACCESSORIES

- Safety View Window (see photo)
- Graphics and Signage
- Public Bike Repair Accessories



301

MODELS

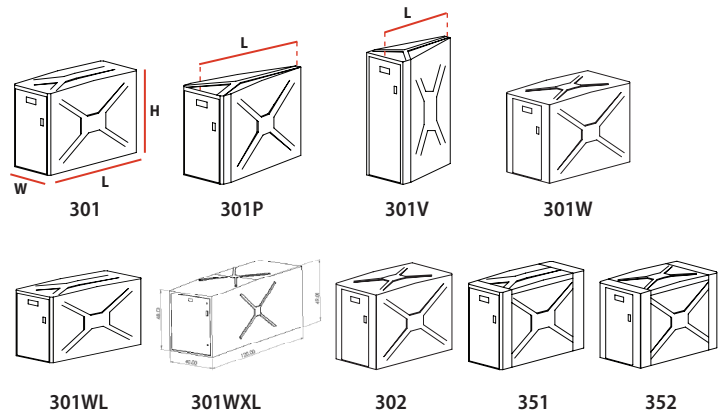

351



301V (Vertical)

STANDARD COLORS

Custom colors available

300 Series

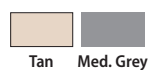

350 Series

